



**World Leader**  
in **Spray Painting**  
**Technology**



**ANEST**  
**IWATA**



...a new star will be born.





## When Innovation becomes the Solution



**ANEST IWATA** is proud to introduce their new company brochure. Our customers and users can find among our products the solutions to many problems of coating applications, improving their working conditions, their safety and the efficiency of their work.

It is our belief that our company mission is to provide all users working in the industrial painting sector, with STATE OF THE ART technology and the constant innovation of equipment for the working process. The fine art, car refinish, wood, leather and plastic, are just a few of the industrial sectors which can be supported by our products and our advice.

**ANEST IWATA's** engagement is to achieve better finishing at a better cost. Our product range also offers users the perfect balance between the use of energy and the effect of the use of energy: in this way, those who choose **ANEST IWATA** become participants in a responsible process for preserving and ameliorating the world around us.

All members of **ANEST IWATA** use their best knowledge and capabilities in order to offer our customers excellent service and high quality products and satisfy them with high quality, reliability, a good reputation and constant innovation.



**HIGH T.E.C. Manual Spray Guns**

W 400	Gravity feed Spray Gun	5
W 400 WB	Gravity feed Spray Gun	5
W 300	Gravity feed Spray Gun	6
W 300 WB	Gravity feed Spray Gun	6
W 200	Pressure feed Spray Gun	7
W 200	Suction feed Spray Gun	7
W 200 WB	Pressure feed Spray Gun	8
W 200 S18	Recirculating Spray Gun	8
W 101	Pressure feed Spray Gun	9
W 101	Suction feed Spray Gun	9
W 101	Gravity feed Spray Gun	9
NEW 71	Manual Spray Gun	10
NEW 77	Manual Spray Gun	10

**LVLP Spray Guns**

LPH 80	Spot Repair Spray Gun	11
LPH 400	Gravity feed Spray Gun	12
LPH 300	Gravity feed Spray Gun	12
LPH 50	Gravity feed Spray Gun	13
RG 3 L	Round Pattern Spray Gun	13

**HIGH T.E.C. Automatic Spray Guns**

WA 200	Automatic Spray Gun	15
WA 100	Automatic Spray Gun	16
WA 77	Automatic Spray Gun	16
LPA 200	Automatic Spray Gun	16
WRA 200 S8	Automatic Spray Gun	17
WRA 100 S9	Automatic Spray Gun	17
WRA 200 S19	Automatic Spray Gun	17

**Non Paint Automatic Spray Guns**

SGA 100	Automatic Spray Gun	18
TOF 5	Automatic Spray Gun	18
TOF 6	Automatic Spray Gun	18

**Electrostatic Equipment**

E-MW50	WB Electrostatic Gun	19
E-MW100	WB Electrostatic Gun	19
E-SC24 EX	Electrostatic Controller	20
E-M15 B	Electrostatic Gun	21
E-SC12 EX	Electrostatic Controller	22

**Double Diaphragm Paint Pumps**

DDP/DPS 90	Diaphragm Paint Pump	23
DDP/DPS 120	Diaphragm Paint Pump	23

**Paint Regulators**

FCV 3	Flow Control Valve	24
FCV 31	Flow Control Valve	24
PR 5 L	Paint regulator	25
PR-B5	Paint regulator	25

**Airless Units**

ALS 333 C	Airless Unit	26
ALS 433 C	Airless Unit	26
ALS 453 C	Airless unit	26
ALS 663/653 N	Airless Unit	27
ALS 423 TX	Airless Unit	27
ALS 433 TX	Airless Unit	27

**Airless Spray Guns**

ALG 7 WB TE	Manual Spray Gun	28
AL 96	Automatic Spray Gun	28

**Bellows Pumps**

MSU B 193	Bellows Paint Pump	29
MSU B 303	Bellows Paint Pump	29
PPS 043	Paint Pump Unit	29

**Extrusion Equipment**

FPP 655	Extrusion Unit	30
FG 6-FG 61-FG 62	Flow gun	30

**Multi Spray Units**

MSU 113 N	Multi Spray Unit	31
MSU 323 C	Multi Spray Unit	32
MSU 323 CTX	Multi Spray Unit	32
MSU 321 N	Multi Spray Unit	32
MSU 423 TX	Multi Spray Unit	33
MSU 433 TX	Multi Spray Unit	33

**Pressure Tanks**

Stainless Steel Paint Pressure Tanks	34	
PC 18D	Pressure Paint Cup	35

**SUITABLE APPLICATIONS REFERENCE** 36**Air GUNSA Spray Guns**

MULTI X	Multi Spray Gun	37
AZ 10 HTE	Suction, Pressure Feed Spray Gun	38
AZ 30 HTE	Gravity Feed Spray Gun	39
AZ 40 HTE	Gravity, Pressure Feed Spray Gun	39
AZ 3 HTE	Gravity Feed Spray Gun	40
AZ 5	Round Pattern Spray Gun	40

**Air GUNSA Garage Equipment**

AE 7	Sprayer	41
S8 - SP8	Air Blowing Gun	41
GI 10 TDP/TLS	Tyre Inflating Equipment	41
P6 - PL6	Washing Gun	42
ST-ST1-ST1S	Sandblasting Gun	42
AZ PVA/TN	Sound-deadening Gun	42

**MIX&SPRAY Cup** 43**Heat T.E.C. series**

INFRA-RED DRYING UNITS	44	
AQUADRY	Paint Dryer Gun	45
32x1R - 32x2R	Paint Heaters	46

**Spray Gun Washers**

INOX LINE SOL	Spray Gun Washer	47
INOX LINE AQUA	Spray Gun Washer	47
INOX LINE SOL+ DISTILLER	Washer + Distiller	48
IWK Combi	Spray Gun Washer	49
IWK H20	Spray Gun Washer	49

**Operator Protection**

Airfed 2100	Full Face Mask	50
Euomask	Half Mask in Rubber	50

**Spray Gun Kits** 51**Two Component Equipment**

Easy Mix	52
Easy Mix 2K	53

**Airbrushes and Compressors**

Custom Micron series	55
Hi-Line series	56
High-Performance Plus series	57
Eclipse series	58
Revolution series	59
Compressors	60

When you see this symbol the product has been tested and is suitable for use with water borne coating materials.





# Standard Atomization Technology

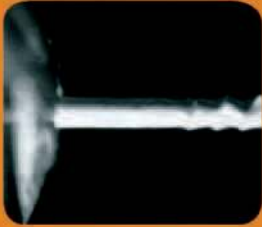

0,05 bar



0,1 bar



0,2 bar

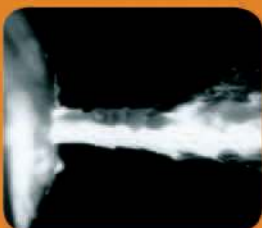

0,3 bar

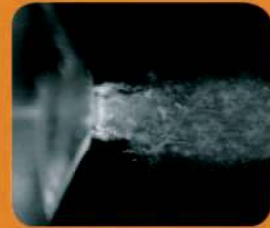

# New Atomization Technology WB



# Mix & Spray

## Rigid Gravity Cup System



1



2



3



4



5



6

- Environmentally friendly
- Only one container for Mixing and Spraying
- Graduated Mixing Cup
- Minimum use of v.o.c. required
- Maximum speed of paint preparation
- The only disposable cup approved for use with ANEST IWATA and AIR GUNSA Spray Guns

- No change of fluid output due to the special air valve
- Anti drip system
- Very low cost

- Save on cleaning time and cleaning materials
- Recyclable or reusable

- No waste of paint inside the cup at the end of paint spraying thanks to the smooth inner surface



## W 400 Gravity

Low air volume general purpose



### CERTIFICATE OF COMPLIANCE

We certify that we have tested the Anest Iwata High T.E.C. W 400 gravity spray gun in accordance with ASTM Designation: D5286-95 Tests for transfer efficiency and that this spray gun complies with the requirements of the Environmental Protection Act 1990, Part 1 - 1997 Revision as detailed in PG6/34(97), PG6/23(97), PG6/40(94), PG6/41(94).

TWO COAT SYSTEM		THREE COAT SYSTEM	
PRIMER	92.0%	PRIMER	92.0%
SOLID COLOUR	76.9%	BASECOAT	76.4%
		CLEARCOAT	74.7%
SYSTEM	84.5%	SYSTEM	81.0%

Signed for MIRRC THATCHAM: M. Smith  
Chief Executive

### CERTIFICATE OF COMPLIANCE

We certify that we have tested (Report Number: TE011) the Anest Iwata W 400 WB Gravity Spray Gun manufactured by Anest Iwata Corporation, in accordance with pr EN 13966-1 Method 2 - tests for paint transfer efficiency (by weight) and that the spray gun complies with the requirements of the UK Environmental Protection Act 1990, Part 1 - 1997 Revision as detailed in PG6/34(97), PG6/23(97), PG6/40(94), PG6/41(94).

Transfer efficiencies achieved with the materials detailed in the test report were:

2K VHS Primer	91.0%
Base coat (Waterborne)	68.7%
Clear coat	77.7%

Signed for MIRRC THATCHAM: Ken Roberts  
Research & Operations Director

**THATCHAM**  
THE MOTOR INSURANCE  
REPAIR RESEARCH CENTRE

Colthroy Way, Thatcham, Berkshire, RG19 4NR U.K.  
Date of Issue: March 2002

## W 400 WB

Low air volume  
for water based base coat



**PRE ATOMIZATION TECHNOLOGY**

Model	Ø mm	bar	Nl/min	ml/min	mm	No.	g		
W400-082G	0.8	2.0	280	60	80	LV2	380 only gun		
W400-102G	1.0			95	150				
W400-122G	1.2			140	175				
W400-132G	1.3			160	225				
W400-142G	1.4			210	225				
W400-152G	1.5			230	250				
W400-162G	1.6			240	270				
W400-182G	1.8			290	320			260	LV1
W400-202G	2.0			360	460			320	R2
W400-251G	2.5			360	580			340	W1

W400WB-101G	1.0	1.8	230	90	230	WB1	380 only gun		
W400WB-121G	1.2			120	260				
W400WB-131G	1.3			140	280				
W400WB-141G	1.4			160	290				
W400WB-131G	1.3			390	140			300	WB2
W400WB-161G	1.6			390	210			340	

Air nipple: G 1/4"

Fluid nipple (gravity) M16 x 1.5mm

CE II 2G X

USE										
W 400 Gravity										
W 400 WB										









**W 200 Pressure**  
General purpose

**W 200 Suction**  
Low air volume  
general purpose

**CERTIFICATE OF COMPLIANCE**

We certify that we have tested the Anest Iwata High T.E.C. W200/WA200/WRA200 pressure feed spray guns in accordance with ASTM Designation: D5286-95 Tests for transfer efficiency and that these spray guns comply with the requirements of the Environmental Protection Act 1990, Part I - 1997 Revision as detailed in PG6/34(97), PG6/23(97), PG6/40(94), PG6/41(94).

Transfer efficiencies achieved with the materials detailed in the test report were:

PRIMER	93.2%
SOLID COLOUR	85.9%
BASECOAT	82.3%
CLEAR LACQUER	73.5%

Signed for MIRRC THATCHAM: M. Smith  
Chief Executive

**THATCHAM**

**CERTIFICATE OF COMPLIANCE**

We certify that we have tested the Anest Iwata High T.E.C. W 200 suction spray gun in accordance with ASTM Designation: D5286-95 Tests for transfer efficiency and that this spray gun complies with the requirements of the Environmental Protection Act 1990, Part I - 1997 Revision as detailed in PG6/34(97), PG6/23(97), PG6/40(94), PG6/41(94).

Transfer efficiencies achieved with the materials detailed in the test report were:

PRIMER	95.2%
SOLID COLOUR	78.9%
BASECOAT	73.8%
CLEAR LACQUER	77.4%

Signed for MIRRC THATCHAM: M. Smith  
Chief Executive

**THATCHAM**  
THE MOTOR INSURANCE  
REPAIR RESEARCH CENTRE  
Cottresp Way, Thatcham, Berkshire, RG19 4NR U.K.

Model	Ø mm	bar	l/min	m <sup>3</sup> /min	mm	No.	g
W200-082 P	0.8	2.0	360	255	280	LV2	380
W200-102 P	1.0						
W200-122 P	1.2						
W200-082 P	0.8	3.0	560	500	400	G2P	
W200-102 P	1.0						
W200-122 P	1.2						

**CERAMIC PAINT**      **NOZZLE/NEEDLE IN TUNGSTEN CARBIDE**

W200-151 ZP	1.5	2.0	500	760	370	R1Z	390
W200-201 ZP	2.0						
W200-251 ZP	2.5						

Air nipple: G 1/4"      Fluid nipple: G 3/8"

**HEAVY VISCOSITY APPLICATIONS**

W2003	2.0	2.9	270	-	300/400	R1	390
W2003	2.5	2.9	360	-	300/400	W1	390

Air nipple: G 1/4"      Fluid nipple: M16x1

W200-152 S	1.5	3.0	330	240	290	K2	380
W200-182 S	1.8						
W200-202 S	2.0						
W200-251 S	2.5						

Air nipple: G 1/4"      Fluid nipple: G 3/8"



CE II 2G X

USE										
W 200 Pressure										
W 200 Suction										







## W 101 Pressure

Low air volume  
general purpose



## W 101 Suction

Low air volume  
general purpose



## W 101 Gravity

Low air volume  
general purpose



Model	Type of feed	Ø mm	bar	l/min	ml/min	mm	No.	g
W101-082P	pressure	0.8	3.0	270	150	190	E2P	295
W101-102P		1.0		270	200	220	E2P	
W101-132P		1.3		220	200	210	E2P	
W101-152P		1.5		220	250	240	E2P	
W101-132S	suction	1.3	2.5	225	150	160	H2	
W101-152S		1.5		225	170	175	H2	
W101-181S		1.8		170	210	170	N1	
W101-101G	gravity	1.0		75	95	130	E1	
W101-132G		1.3		225	160	175	H2	
W101-152G		1.5		225	190	190	H2	
W101-181G		1.8		170	240	190	N1	

Air nipple: G 1/4"

Fluid nipple: G 1/4"

CE  $\epsilon x$  II 2G X

USE													
W 101 Pressure													
W 101 Suction													
W 101 Gravity													



**NEW 71**  
General purpose

**Certificate**

The Fraunhofer IPA certifies that the

**ANEST IWATA New 71-0 spray gun**  
fitted with a 0.8 mm nozzle  
applying a gun inlet pressure of 1.5 bar and a pump controlled paint feed  
of 220 g/min of a water-base wood stain

has been tested in accordance to EN 13966-1 (VDMA german technical rule 24 366) and  
found to have a transfer efficiency of 87%.

January 2006  
  
Dipl.-Ing. (FH) S. Paustian  
Responsible Scientist

**Fraunhofer**  
Institut  
Produktionstechnik  
und Automatisierung

www.aitgursa.com



**NEW 77**  
General purpose

**Certificate**

The Fraunhofer IPA certifies that the

**ANEST IWATA New 77-0 spray gun**  
fitted with a 1.2 mm nozzle  
applying a gun inlet pressure of 2.0 bar and a pump controlled paint feed  
of 480 g/min of a solvent-base 2-K-Finish for wood

has been tested in accordance to EN 13966-1 (VDMA german technical rule 24 366) and  
found to have a transfer efficiency of 82%.

January 2006  
  
Dipl.-Ing. (FH) S. Paustian  
Responsible Scientist

**Fraunhofer**  
Institut  
Produktionstechnik  
und Automatisierung

Certification available on www.aitgursa.com

Model	Ø mm	bar	l/min	ml/min	mm	No.	g
NEW 71 0	0.8	3.5	240	200	190	0	470
NEW 71 1S	1.0	3.0	75	95	100	1S	
NEW 71 2S	1.3		85	135	135	2S	
NEW 71 3S	1.5		165	180	170	3S	
NEW 71 4S	1.8		230	195	200	4S	
NEW 71 21S	1.3		195	140	155	21S	
NEW 71 31S	1.5		230	170	170	31S	
NEW 71 1G	1.0		75	110	120	1G	
NEW 71 2G	1.3		85	155	155	2G	
NEW 71 3G	1.5		165	210	185	3G	
NEW 71 4G	1.8		230	220	230	4G	
NEW 71 21G	1.3		195	160	165	21G	
NEW 71 31G	1.5		230	190	185	31G	

Air Nipple: G 1/4" Fluid Nipple: G 1/4"

NEW 77 0	1.2	3.5	430	480	445	0	550
NEW 77 1S	1.5		180	255	210	1	
NEW 77 2S	2.0		250	345	255	2	
NEW 77 3S	2.5		325	435	280	3	
NEW 77 1G	1.5		180	285	230	1	
NEW 77 2G	2.0		250	390	290	2	
NEW 77 3G	2.5		325	485	330	3	

Air Nipple: G 1/4" Fluid Nipple: G 3/8"

CE II 2G X

USE												
NEW 71												
NEW 77												









# RECOMMENDATION CHARTS

**DU PONT** RECOMMENDATION CHART  
www.aneef-ivtaceu.com

**AUTOCOLOR** RECOMMENDATION CHART  
www.aneef-ivtaceu.com

**PPG AUTO REFINISH** RECOMMENDATION CHART  
www.aneef-ivtaceu.com

**AKZO NOBEL** RECOMMENDATION CHART  
www.aneef-ivtaceu.com

Application	Product	Spray Gun Model				
		W400 WE1	W400 L22	W300 WE	LPH80	A220 HTE
BASE COAT	Primer					
	Base Coat					
CLEAR COAT	Clear Coat					
	Clear Lacquer					
MICRO REPAIR	Spot System					
	Micro Repair					



European Directives:  
1999/13/CE - 2004/42/CE

### Guidelines:

- Use products in compliance.
- Use spray guns with High Transfer Efficiency.
- Use products within enclosed areas.
- Respect hygiene and safety regulations.

Trade Marks are property of the depositor

### Maximum VOC content limit values for paints and varnishes:

PRODUCT	MAX. VOC CONTENT LIMIT FOR PRODUCTS (g/l)
Preparatory and cleaning	850
Pre-cleaner	200
Bodyfiller/stopper (all types)	250
Wash primer	780
Surface/filler and general (metal) primer	540
Top coat/Single coat	420
Base coat	420
Clear lacquer	420
Special finishes	840





**WA 200**  
General purpose

**CERTIFICATE OF COMPLIANCE**

We certify that we have tested the Anest Iwata High T.E.C.W200/WA200/WRA200 pressure feed spray guns in accordance with ASTM Designation: D5286-95 Tests for transfer efficiency and that these spray guns comply with the requirements of the Environmental Protection Act 1990, Part I - 1997 Revision as detailed in PG6/34(97), PG6/23(97), PG6/40(94), PG6/41(94).

Transfer efficiencies achieved with the materials detailed in the test report were:

PRIMER	93.2%
SOLID COLOUR	85.9%
BASECOAT	82.3%
CLEAR LACQUER	73.5%

Signed for MIRRC THATCHAM: ..... M. Smith  
Chief Executive

**THATCHAM**  
THE MOTOR INSURANCE  
REPAIR RESEARCH CENTRE  
Colthrop Way, Thatcham, Berkshire, RG19 4NR U.K.

## WA 200 ZP

With nozzle / needle in tungsten carbide for ceramic industry

## WA 200 FT

With Flat & Thin fan pattern for leather and wood industry



Model	Ø mm	bar	l/min	ml/min	mm	No.	g				
WA200 062	0.6	2.0	270	255	280	LV2	500				
WA200 084	0.8										
WA200 104	1.0										
WA200 124	1.2										
WA200 154	1.5										
WA200 082P	0.8	3.0	530	500	400	G2P					
WA200 102P	1.0										
WA200 122P	1.2										
WA200 152P	1.5							330	270	340	K2
WA200 202P	2.0							360	400	320	R2
WA200 251P	2.5						360	500	330	W1	

WA200 151 ZP	1.5	3.0	330	270	340	R1Z	500
WA200 201 ZP	2.0	3.0	360	400	320		
WA200 251 ZP	2.5	3.0	360	500	330		

WA200-066P FT	0.6	0.14	170	80	140	FT6	550
WA200-086P FT	0.8	0.16	185	100	150		
WA200-106P FT	1.0	0.18	200	120	160		
WA200-126P FT	1.2	0.20	220	140	180		

Air nipple: G 1/4"

Fluid nipple: G 3/8"



USE												
WA 200												
WA 200 ZP												
WA 200 FT												







## WRA 200 S8

Robot Applications



### CERTIFICATE OF COMPLIANCE

We certify that we have tested the Anest Iwata High T.E.C.W200/WA200/WRA200 pressure feed spray guns in accordance with ASTM Designation: D5286-95 Tests for transfer efficiency and that these spray guns comply with the requirements of the Environmental Protection Act 1990, Part I - 1997 Revision as detailed in PG6/34(97), PG6/23(97), PG6/40(94), PG6/41(84).

Transfer efficiencies achieved with the materials detailed in the test report were:

PRIMER	93.2%
SOLID COLOUR	85.9%
BASECOAT	82.3%
CLEAR LACQUER	73.5%

Signed for MIRRC THATCHAM: .....

M. Smith  
Chief Executive



Colthrop Way, Thatcham, Berkshire, RG19 4NR U.K.



**WB version** available



## WRA 200 S19

With ROBOT ARM



## WRA 100 S9

Robot Applications

Model	Ø mm	bar	Nl/min	m³/min	mm	No.	g
WRA 200 S8	1.2	2.4	530	500	460	E2P	460
Air nipple: G 1/4"					Fluid nipple: G 1/4"		
WRA 100 S9	0.4	0.9	380	350	280	-	400
WRA 100 S9	0.6		400		280	-	
WRA 100 S9	1.0		450	380	300	-	

Air Nipple / Fluid Nipple: quick connector

WRA200 S19 08P	0.8	1.5	420	150	200	WB1	1030
WRA200 S19 10P	1.0			200	240		
WRA200 S19 12P	1.2			250	260		
WRA200 S19 14P	1.4			250	280		

CE II 2G X

USE															
WRA 200 S8															
WRA 100 S9															
WRA 200 S19															





## Electrostatic Spray Guns for Water Based Paints

### EXTERNAL CHARGE: NO NEED FOR INSULATING SYSTEM

- Detachable external electrode
- Maximum output: -50 kv (E-MW50) -60 kv (E-MW100)
- High voltage generation: internal elevator
- Input voltage: AC24pp (the gun is fed with low voltage)
- Maximum operating current: 150  $\mu$ A
- Length without electrode: 186 mm (E-MW50) 183 mm (E-MW100)
- Length with electrode: 212 mm (E-MW50) 229 mm (E-MW100)



**E-MW50**

Designed for better handling



**E-MW100**

Designed for better electrostatic effect

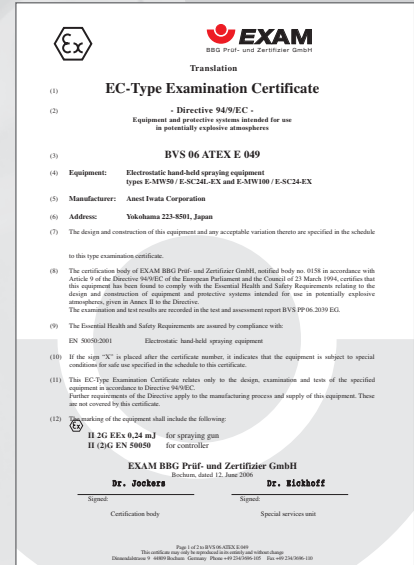
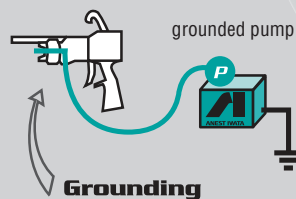
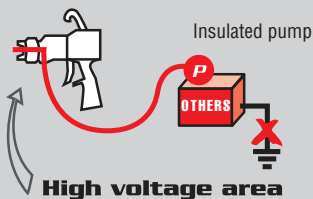

**CE** **Ex** II 2G EEx 0,24 mJ  
KEMA 0344 EN50050 group II, category 2 gas atmosphere equipment  
BVS06ATEXE049 suitable for use in zone 1

Model	Ø mm	No.	L.V.	H.V.	m	g
E-MW50-11C5X	1.1	C5	AC24Vpp	DC-50kV	10	530
E-MW50-11C5Y	1.1	C5	AC24Vpp	DC-50kV	15	530
E-MW50-11C5Z	1.1	C5	AC24Vpp	DC-50kV	20	530
E-MW100-11C5X	1.1	C5	AC24Vpp	DC-60kV	10	595
E-MW100-115Y	1.1	C5	AC24Vpp	DC-60kV	15	595
E-MW100-11C5Z	1.1	C5	AC24Vpp	DC-60kV	20	595

USE												
E-MW50												
E-MW100												



# ELECTROSTATIC CONTROLLERS

## EXTERNAL CHARGE



### E-SC24-EX

For E-MW100 series

### E-SC24L-EX

For E-MW50 series

## FOR AUTOMAKERS AND GENERAL INDUSTRIES

**Intelligent controller maximizes performance of compact electrostatic gun.**

- Digital set up:
  - Voltage
  - Current
- Full functions of safety detection:
  - Grounding
  - Low voltage cable failure alarm
  - Current overload alarm
- Function to keep record of alarms
- Advanced voltage and current control by microcomputer
- Size: D 160 x W 245 x H 130 mm

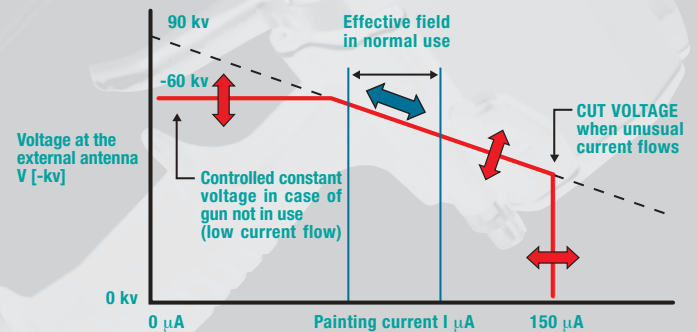
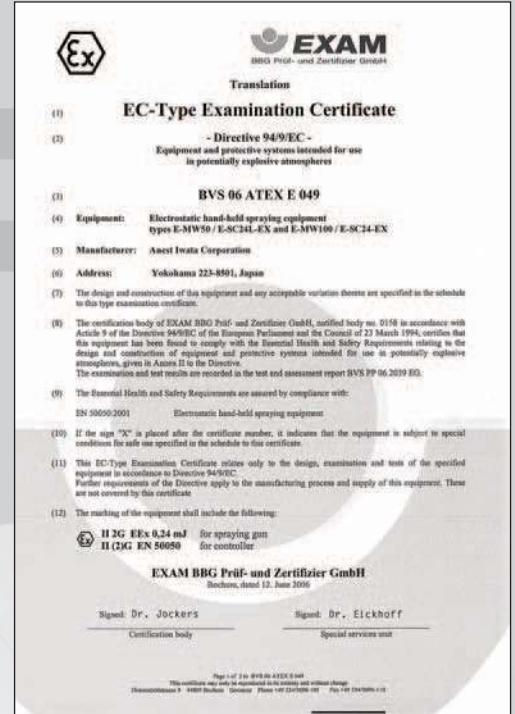

E-SC24-EX E-SC24-EX	AC200-240V	UK	
E-SC24-EX-S1 E-SC24L-EX-S1	AC200-240V with external output*		
E-SC24-EX-i E-SC24-EX-i	AC200-240V	Italy	
E-SC24-EX-S1-i E-SC24L-EX-S1-i	AC200-240V with external output*		
E-SC24-EX-F E-SC24-EX-F	AC200-240V	France Germany	
E-SC24-EX-S1-F E-SC24L-EX-S1-F	AC200-240V with external output*		

CE II (2)G EN 50050

KEMA 0344 EN50050 to be installed only in safe area  
BVS06ATEXE049

\* External signal output option type.  
Specifications: Power on/off - Charge on/off - Failure on/off - Current flow caution



## E-M15B

For general paints



**Round pattern air cap set**

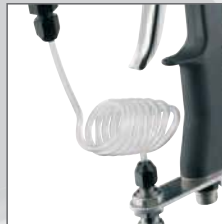

**Spiral fluid tube set**

## INTERNAL CHARGE

### Effective & Ecological

Fulfills high transfer efficiency with even -40 kV by means of atomizing head to maintain fine finishing and maximize electrostatic effect.

### Safety

Cascade type high safety feature.

### Ergonomics

Ergonomically designed trigger and grip supported by feedback from many users.

### Easy

Low voltage cable with detachable connector for easy maintenance. Teflon fluid hose which is easy to clean and maintain.



### EG-Baumusterprüfbescheinigung

- (1) **Richtlinie 94/9/EG - Geräte und Schutzsysteme zur explosionsgefährdeten Verwendung in explosionsgefährdeten Bereichen**
- (2) **BVS 05 ATEX E 027**
- (3) **Gerät:** Elektrostatische Sprühpistolen, Typen: E-M10B, E-M15B, E-EX-121B, E-EX-121C und Steuergerät Typ E-AC12-EX
- (4) **Hersteller:** ANEST IWATA Corporation
- (5) **Anschriß:** Yokohama, JAPAN
- (6) Die Bauart dieses Gerätes sowie die verschiedenen zulässigen Ausführungen sind in der Anlage zu dieser Baumusterprüfbescheinigung festgelegt.
- (7) Die Zertifizierungsstelle der EXAM BGG Prüf- und Zertifizier GmbH, besonnte Stelle Nr. 0158 gemäß Artikel 9 der Richtlinie 94/9/EG des Europäischen Parlaments und des Rates vom 21. März 1994, bescheinigt, dass das Gerät die gasführenden Sicherheits- und Gasabfuhranforderungen für die Konstruktion und den Bau von Geräten und Schutzsystemen zur explosionsgefährdeten Verwendung in explosionsgefährdeten Bereichen gemäß Anhang II der Richtlinie erfüllt. Die Ergebnisse der Prüfung sind in dem Prüfprotokoll BVS PP 05.2015 BGG anbei angelegt.
- (8) Die grundlegenden Sicherheits- und Gesundheitsanforderungen werden erfüllt durch Übersetzung mit EN 20090:2001 Elektrostatische Hochspannungsrichtungen
- (9) Falls die Zeichen „C“ Meiner der Bauartleistungsnummer steht, wird in der Anlage zu dieser Bauartprüfung auf besondere Bedingungen für die sichere Anwendung des Gerätes hingewiesen.
- (10) Diese EG-Baumusterprüfbescheinigung bezieht sich nur auf die Konstruktion und die Bauartprüfung der beschriebenen Geräte in Übereinstimmung mit der Richtlinie 94/9/EG. Für Herstellung und in Verkehr bringen des Gerätes sind weitere Anforderungen der Richtlinie zu erfüllen, die nicht durch diese Bauartprüfung abgedeckt sind.
- (11) Die Kennzeichnung des Gerätes muss die folgenden Angaben enthalten:
  - Sprühpistole: II 2G EEx 0,24 mJ
  - Steuergerät: II (2)G EEx 0,24 mJ

EXAM BGG Prüf- und Zertifizier GmbH

Bodense, den 15. März 2005

*J. Kersch*  
Zertifizierungsstelle

*A. Kersch*  
Fachstelle

## FOR AUTOMAKERS AND GENERAL INDUSTRIES

Model	Ø mm	No.	L.V.	H.V.	m	g
E-M15B-13C1X	1.3	C1	AC12Vpp	DC-40kV	10	510
E-M15B-13C1Y	1.3	C1	AC12Vpp	DC-40kV	15	510
E-M15B-13C1Z	1.3	C1	AC12Vpp	DC-40kV	20	510
E-M15B-13L1X	1.3	L1	AC12Vpp	DC-40kV	10	510
E-M15B-13L1Y	1.3	L1	AC12Vpp	DC-40kV	15	510
E-M15B-13L1Z	1.3	L1	AC12Vpp	DC-40kV	20	510

**CE** **Ex** II 2G EEx 0,24 mJ

KEMA 0344 EN50050 group II, category 2 gas atmosphere equipment suitable for use in zone 1  
BVS05ATEXE027

USE															
E-M15B															

## INTERNAL CHARGE



**E-SC12-EX**  
For E-MW100 series

## FOR AUTOMAKERS AND GENERAL INDUSTRIES

**Intelligent controller maximizes performance of compact electrostatic gun.**

- Overcurrent relay (OCR).
- Ground failure detection.
- Shielded cable failure detection.
- Metallic bridge avoidance function.
- Self-diagnostic failure display function.
- Size: D150 x W200 x H130 mm



**CE** **Ex** II (2)G EEx 0,24 mJ

KEMA 0344 EN50050 to be installed only in safe area  
BVS05ATEXE027

<b>E-SC12-EX</b>	AC200-240V	<b>UK</b>	
<b>E-SC12-EX-S1*</b>	AC200-240V with external output*		
<b>E-SC12-EX-1</b>	AC200-240V	<b>Italy</b>	
<b>E-SC12-EX-S1-I*</b>	AC200-240V with external output*		
<b>E-SC12-EX-FD</b>	AC200-240V	<b>France Germany</b>	
<b>E-SC12-EX-S1-FD*</b>	AC200-240V with external output*		

\* External signal output option type.  
Specifications: Power on/off - Charge on/off - Failure on/off - Low current detection





DDP 90



**DPS 90**  
Industrial Painting



**Versions:**  
**DPS 90 F** Aluminium  
**DPS 90 FN** Stainless Steel

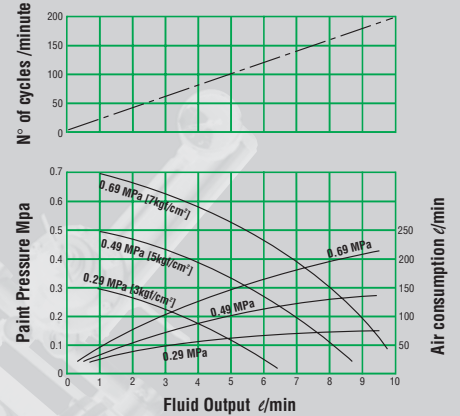

**DPS 120**  
Industrial Painting



DDP 120

**Versions:**  
**DPS 120 B** Aluminium  
**DPS 120 B WB** Teflon Coated

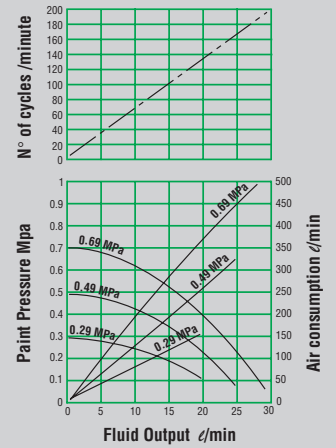

CE  $\text{\textcircled{E}}$  II 2G T6 X

Model							
	n:n	bar	bar	m <sup>3</sup> /cycle	cycles/min	$\ell$ /min	mesh
DPS 90 F / DPS 90 FN	1:1	6.8	6.8	50	200	10	50
DPS 120 B / DPS 120 B WB	1:1	6.8	6.8	150	200	30	50

USE											
DPS 90 F / DPS 90 FN											
DPS 120 B / DPS 120 B WB											





## PR-5L

For diaphragm pumps  
(pressure ratio 1:1)

- Max fluid output: 2.0 l/min
- Max. pressure output:  
from 0 to 3 bar
- Fluid joint input G 3/8"
- Fluid joint output G 1/4"

### Versions:

- Stainless Steel
- Aluminium
- Teflon Coated



## PR-B5

### BACK PRESSURE VALVE

Touch-up Work Spray Gun

- Pressure range: 0÷6 bar
- Max. flow: 2.0 l/min
- Max. primary pressure: 20 bar

**Available**  
in two versions:  
**PR-B5 or PR-B5 N\***

\*Stainless Steel

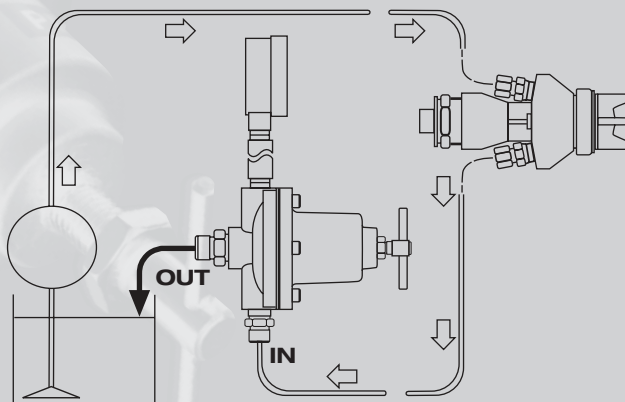

CE II 2G X

USE											
PR-5L											
PR-B5											







## ALS 653 N / ALS 663 N

Suitable for low-medium-high viscosity paints



ALS 663-653 Performance Curve

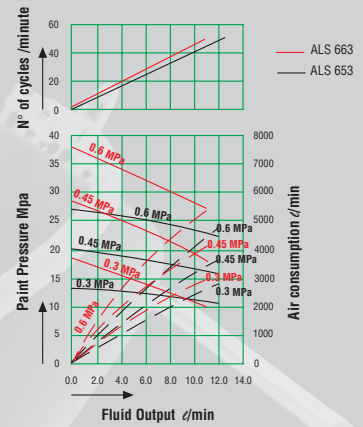

## ALS 423 TX

Suitable for high-viscosity paints and thixotropic paints

ALS 433 Performance Curve

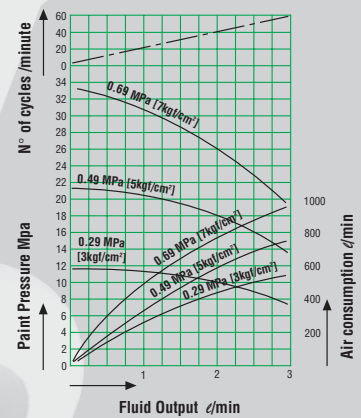

## ALS 433 TX

Suitable for high-viscosity paints and thixotropic paints



Model	n:n	bar	bar	m/cycle	cycles/min	/min	mesh	mesh
ALS 653 N	45:1	270	6.0	250	50	12.5	60	30
ALS 663 N	63:1	378	6.0	220	50	11.0	60	30
ALS 423 TX	23:1	156	6.8	80	100	8.0	100	30
ALS 433 TX	30:1	204	6.8	59	80	4.7	100	30

CE II 2G T6 X

USE												
ALS 653 N / ALS 663 N												
ALS 423 TX												
ALS 433 TX												





## MSU B193 / MSU B303

Suitable for High-viscosity paints and thixotropic paints



## PPS B043

Paint Pump Set  
Suitable to feed automatic systems and to transfer paints



Model							
	n:n	bar	bar	ml/cycle	l/min	mesh	mesh
MSU B303	30:1	180	6.0	133	13	100	30
MSU B193	19:1	114	6.0	133	12	100	30
PPS B043	4:1	24	6.0	628	60	-	-



USE											
MSU B193 / MSU B303											
PPS B043											







## MSU 113 N

- Small size pump.
- Suitable for spraying medium quantity of paint with frequent colour changes, saves time and solvents in cleaning operations.
- Suitable for Water Based Paints
- Pressure ratio 13:1 suitable for use with:



MSU 113 N Performance Curve

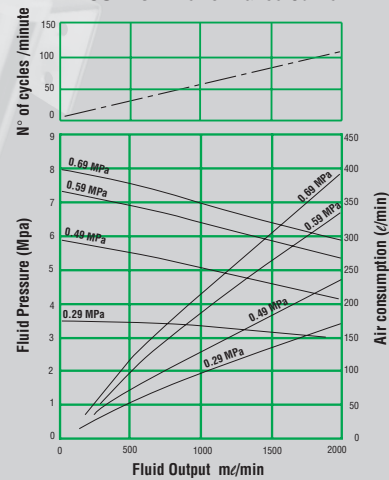

Model								
MSU 113 N	13:1	88	6.8	17	110	1,9	100	50

CE II 2G T6 X

USE											
MSU 113 N											





## MSU 423 TX

Suitable for low-medium viscosity paints



## MSU 433 TX

Suitable for low-medium-high viscosity paints and Thixotropic paints



CE  $\text{\textcircled{E}}$  II 2G T6 X

Model	n:n	bar	bar	ml/cycle	cycles/min	l/min	mesh	mesh
MSU 423 TX	23:1	156	6.8	80	100	8	100	30
MSU 433 TX	30:1	204	6.8	59	80	4.7	100	30

USE											
MSU 423 TX											
MSU 433 TX											







## PC 18 D

- Air regulator
- Safety valve
- Check valve



**Available**  
in two versions:

**PC 18 D** or **PC 18 DT\***

\*T = Teflon

AIR TRANSFORMER  
(option)

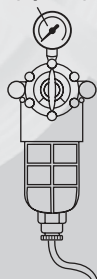

AIR HOSE  
(option)

SPRAY GUN  
(option)



FLUID HOSE  
(option)



CE Ex II 2G T6 X

USE											
PC 18 D											



# SUITABLE APPLICATIONS REFERENCE

	MODEL	PUMP TYPE	MANUAL AIR SPRAY	MANUAL AIR ASSISTED AIRLESS SPRAY	MANUAL AIRLESS SPRAY	EXTRUSION (EX. CAULKING)	MANUAL FLOW COATING (NO ATOMIZATION)	PAINT TRANSFER & CIRCULATION	AUTOMATIC COATING (SINGLE GUN)	AUTOMATIC COATING (PLURAL GUNS)	APPLICATIONS
AIRLESS UNIT	ALS 333 C	plunger			●				●		
	ALS 433 C	plunger			●				●		
	ALS 453 C	plunger			●				●		
	ALS 423 TX	plunger			●				●	●	
	ALS 433 TX	plunger			●				●	●	
	ALS 653	plunger			●				●	●	
	ALS 663	plunger			●				●	●	
MULTI SPRAY UNIT	MSU 113 N	plunger		●					●		
	MSU 321 N	plunger		●					●		
	MSU 323 C	plunger		●					●		
	MSU 323 CTX	plunger		●					●		
	MSU 423 TX	plunger		●	●				●	●	
	MSU 433 TX	plunger		●	●				●	●	
	MSU B193	bellows		●					●	●	
	MSU B303	bellows		●	●				●	●	
DDP	PPS B043	bellows	●			●		●		●	
	FPP 655	plunger					●				
	DPS 90 F	diaphragm	●						●	●	
	DPS 90 FN	diaphragm	●						●	●	
	DPS 120 B	diaphragm	●						●	●	
	DPS 120 B WB	diaphragm	●						●	●	

	MODEL	PUMP TYPE	SOLVENT BASED PAINT	WATER BASED PAINT	LOW VISCOSITY	MEDIUM VISCOSITY	HIGH VISCOSITY	HIGH VISCOSITY & THIXOTROPIC	PAINTS
AIRLESS UNIT	ALS 333 C	plunger	●		●	●			
	ALS 433 C	plunger	●		●	●			
	ALS 453 C	plunger	●		●	●			
	ALS 423 TX	plunger	●	●	●	●	●	●	
	ALS 433 TX	plunger	●	●	●	●		●	
	ALS 653	plunger	●		●	●	●		
	ALS 663	plunger	●		●	●	●		
MULTI SPRAY UNIT	MSU 113 N	plunger	●	●	●	●			
	MSU 321 N	plunger	●	●	●	●			
	MSU 323 C	plunger	●		●	●	●		
	MSU 323 CTX	plunger	●	●	●	●			
	MSU 423 TX	plunger	●	●	●	●		●	
	MSU 433 TX	plunger	●	●	●	●		●	
	MSU B193	bellows	●	●	●	●		●	
	MSU B303	bellows	●	●	●	●		●	
DDP	PPS B043	bellows	●	●	●	●	●	●	
	FPP 655	plunger	●				●		
	DPS 90 F	diaphragm	●		●	●			
	DPS 90 FN	diaphragm	●	●	●	●			
	DPS 120 B	diaphragm	●		●	●			
	DPS 120 B WB	diaphragm	●	●	●	●			

## MULTI X



### MULTI X

Air Assisted Airless Spray Gun



- Fluid pattern adjustment up to 30%
- Easy adjustment of the spring force according to the pressure of the fluid sprayed
- Easy maintenance: (disassembling of the needle from the back)
- Suitable for solvent and water based paints
- Suitable for low - medium - high viscosity paints and thixotropic paints
- Paint passage parts in Stainless Steel
- Needle valve in Tungsten Carbide



Easy cleaning:  
the fluid tip can be inverted  
inside the air cap  
(tool supplied with the gun)

#### NOZZLE TIP RANGE











ORIFICE SIZE Ø (inches)	AVAILABLE							FLUID OUTPUT (ml/min)
	15°	20°	25°	35°	40°	50°	65°	
.007"			•	•	•			176 - 220
.009"		•			•	•	•	240 - 300
.011"			•		•	•	•	300 - 380
.013"			•		•	•	•	480 - 560
.015"	•		•		•	•	•	620 - 700
.018"			•		•	•		1000 - 1060
PATTERN WIDTH (25 cm distance)								
	08-12	10-14	10-14	12-16	14-18	18-22	22-26	

How to order: W2TIP + Ø orifice size (take off first zero) + desired angle (in degrees)  
For example: W2TIPO725 to have a tip 0,007" with a 25° angle



CE  II 2 G X

Model	 g	 bar	 bar	 mesh
MULTI X	540	150	7.0	200

USE											
MULTI X											







## AZ 30 HTE

High Performance Spray Gun



<b>Model</b>	<b>AZ30 HTE</b>		
<b>Test Board</b>	Efficienza di trasferimento I.P.A.		
<b>Date</b>	25/04/2005		
Transfer efficiencies achieved with the materials detailed in the test report were:			
<b>TWO COAT SYSTEM</b>		<b>THREE COAT SYSTEM</b>	
PRIMER	88 %	PRIMER	88 %
SOLID COLOUR	72 %	BASE COAT	83 %
		CLEARCOAT	74 %
SYSTEM	80 %	SYSTEM	82 %



### COMPLIANCE

by the Air Gunsa AZ 40 HTE s.r.l. in accordance with the Environmental Protection Act

PG6/41(94), PG6/23(97), PG6/40(94), PG6/41(94).

Transfer efficiencies achieved with the materials detailed in the test report were:

Water Based Base Coat	72.1%
2K HS Lacquer (Clearcoat)	75.7%
2K VHS Primer	93.0%

Signed for MIRRC THATCHAM:

Ken Roberts

Research & Operations Director

### THATCHAM

THE MOTOR INSURANCE REPAIR RESEARCH CENTRE

Colthrop Way, Thatcham, Berkshire, RG19 4NR U.K.

Date of Issue August 2001

## AZ 40 HTE

Gravity Spray Gun



**HTE**  
HIGH TRANSFER EFFICIENCY

Model	Ø mm	bar	Nl/min	m <sup>3</sup> /min	mm	No.	g
AZ 30 HTE	1.0	2.5	245	80	150	10 HP	490 only gun
	1.3		245	175	225	13 HP	
	1.5		250	220	260	15 HP	
	1.8		270	280	325	18 HP	
	2.0		270	315	350	20 HP	

Max. Working Pressure: 7.0 bar (98 PSI)

Noise Level (LAeqT) 73.5 dB (A)

Temperature range: 5~40° C

Air nipple: G 1/4"

Fluid nipple: G 1/4"

Model	Ø mm	bar	Nl/min	m <sup>3</sup> /min	mm	No.	g
AZ40 HTE	0.8	2.5	130	60	100	510	PCG AZ 600 140
	1.0		130	90	110		
	1.2		130	120	130		
	1.5		170	170	140		
	1.8		200	210	150		
AZ40 HTE AV	2.0	2.5	200	230	160	415	PCG AZ 200 80
	0.8		130	100	150		
	1.0		130	100	160		
	1.2		130	150	170		
	1.5		170	200	190		
AZ40 H SPT E	1.8	2.5	200	250	200	425	NO
	2.0		200	250	210		
	1.8		200	250	200		

Max. Working Pressure: 7.0 bar (98 PSI)

Noise Level (LAeqT) 75.6 dB (A)

Temperature range: 5~40° C

Air nipple: G 1/4"

Fluid nipple: G 1/4"



## AZ 40 HTE SP

Pressure Spray Gun

**NEW inlet Air Valve**

CE  $\epsilon_x$  II 2G T6 X

USE												
AZ 30 HTE												
AZ 40 HTE												







**AE 7**

Spray Gun



- Sprayer for mixed air and water
- Suitable for all washing and cleaning operations
- It is possible to control the quantity of liquid used and have a concentrated spray

<b>Air joint</b>	1/4" BSP M
 <b>Total weight</b>	840
 <b>Air consumption</b>	294 l/min a 6 bar
<b>Fluid connection</b>	3/8" BSP M
<b>Fluid nozzle extension</b>	210 mm



**SP8**

Blow Gun

Model	S8	SP8
 <b>Total weight</b>	275	350
 <b>Air consumption</b>	175 l/min a 6 bar	
<b>Fluid nozzle extension</b>	-	240 mm
<b>Air joint</b>	G 1/4" M	
<b>Alluminium body</b>		

**Blowing equipment for removing dust and powder. Suitable for garages and industry in general.**



**GI10 TDP/TLS**

Tyre Inflating Equipment



**High precision pressure gauge according to E.C. regulations**

- reading scale from 0 to 10 bar
- reading precision ± 1% up to 4 bar



**P6 - PL6**

**P6** fluid nozzle extension 260 mm

**PL6** fluid nozzle extension 500 mm

Sprayer for oil, fuel, petroleum and detergents. Suitable for washing, graphitizing and lubricating operations



**ST 1 - ST 1S - ST**

Sandblasting gun

**ST 1**

- Sandblasting gun with container
- Suitable for small jobs

**ST 1S**

- Self-priming sandblasting gun
- Suitable for treating medium-small areas

**ST**

- Self-priming sandblasting gun
- Suitable for treating large areas



**AZ PVA - AZ PVA TN**

Spray Guns for Body Coatings

**AZ PVA**

Spray Gun, with suction feed and internal mixing. Suitable for applying body coatings and dense materials.

**AZ PVA TN**

Spray gun, with suction feed and internal mixing. Suitable for applying soundproofing coatings to be used with pre-packed paintpot.





## Mix&Spray

Rigid Gravity Cup System

- Environmentally friendly.
- Only one container for Mixing and Spraying.
- Graduated Mixing Cup.
- Minimum use of v.o.c. required.
- Maximum speed of paint preparation.
- The only disposable cup approved for use with ANEST IWATA and AIR GUNSA Spray Guns.
- No change of fluid output due to the special air valve.
- Anti drip system.
- Very low cost.
- Save on cleaning time and cleaning materials.
- Recyclable or reusable.
- No waste of paint inside the cup at the end of paint spraying thanks to the smooth inner surface.

## Adaptors

For Mix&Spray Cup



**W2COM5017**  
Sata

**W2COM518K**  
DeVilbiss



USE										
Mix&Spray Cup										
Adaptors										



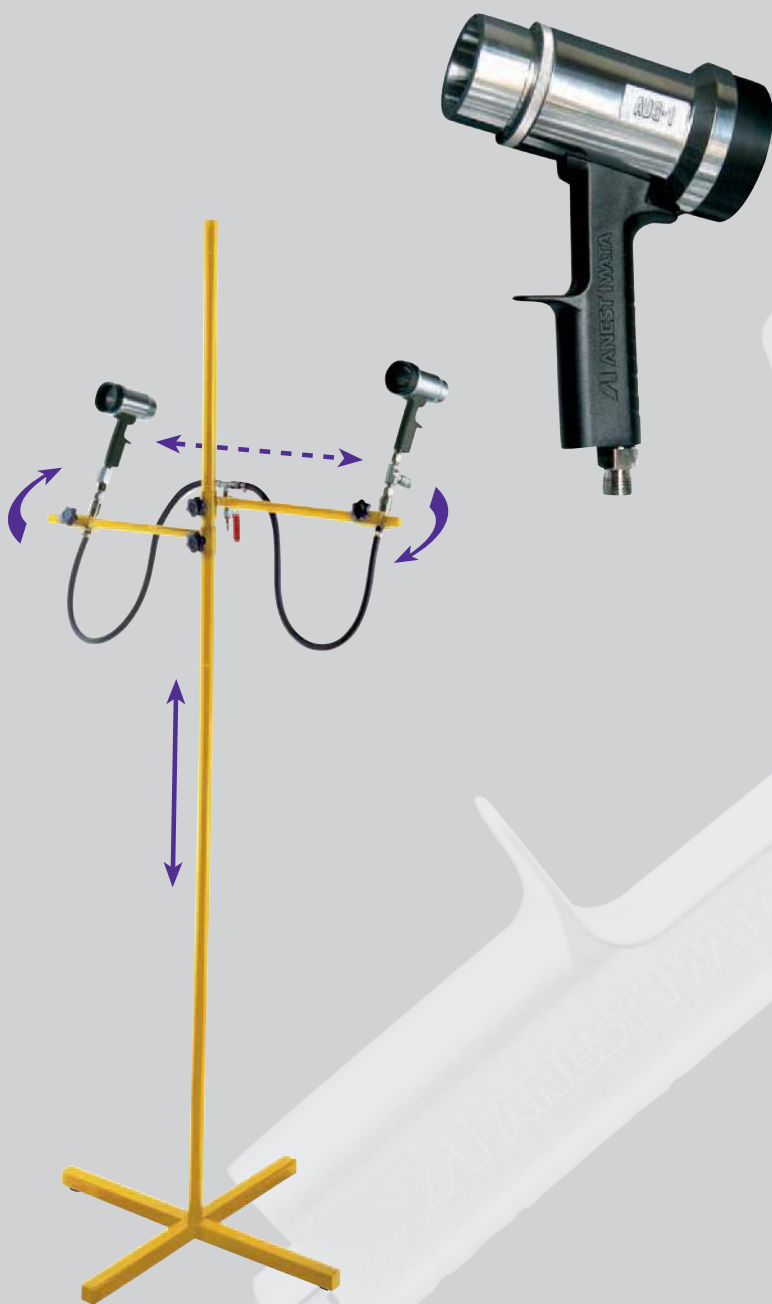

## Aquadry

Indispensable Kit  
for the Accelerated Drying  
of Waterbased Coatings

- The guns are provided with quick couplings which allow fast disassembly.
- Air regulator included
- Guns are easily adjustable
- Each gun can be used independently
- Venturi air entrainment increases air flow by 6:1
- The stand has a slide and lock height adjustment.  
The gun brackets can be moved along the length of the arm and positioned to suit.  
The height of stand is 180 cm  
The width of arm is 80 cm (38,5 each side), and it supports 2 aquadry guns
- Variable air flow
- Max pressure: 7 bar
- Max air consumption: 2 x 600 l/min

CE

USE												
Aquadry												







## Inox Line SOL mod. SLD

- Stainless Steel Electroclean Body and Tank
- Automatic wash with clean solvent rinse
- Manual wash available
- Test booth and exhaust
- Drying gun
- Possible to connect to a Distiller



## Inox Line AQUA mod. ILA

- Stainless Steel (Electroclean) Spray Gun Washer
- Available for automatic and manual washing and final rinse
- Equipped with diaphragm pump for automatic washing and Venturi pump for manual washing
- Includes blowing gun
- Water/paint separation device
- Brush connected to water supply
- The unit incorporates an exhaust system for colour spray tests



CE Ex II 2 G X

USE										
Inox Line Sol mod. SLD										
Inox Line Aqua mod. ILA										





## IWK COMBI

### SOL B - SLB

This machine with suction feed is provided with an exhaust, outer supporting bench for guns and a lower manhole. It also has a timer-controlled diaphragm pump for automatic washing, a nozzle, and a compressed-air-hose for final manual washing and small spraying work.

### SOL C - SLC

This machine is equipped as the IWK SOL B model, with an additional diaphragm pump for final automatic rinsing.

### IWK H<sub>2</sub>O

Spray Gun Washer

## IWK H<sub>2</sub>O



### SPRAY GUN WASHER IWK H<sub>2</sub>O

air pressure	8 bar min - 10 bar max
operation	pneumatic
exhaust duct diameter	cm 15
useful dimensions of washing tank	cm 50 x 40 x 27h
external dimension	cm 45 x 66 x 133,5h
total weight	44 kg

CE II 2 G X

USE												
IWK Combi												
IWK H <sub>2</sub> O												







## REFINISHING KIT MASTER

- High T.E.C. Spray Gun
- M&S CUP (600 cc):
  - 3 cups + 3 inner lids + 3 knobs + 3 plugs
  - 1 paint filter 125  $\mu$
  - 1 paint filter 250  $\mu$
  - 1 screen paint filter 125  $\mu$  for inner lid
  - 1 cup holder + 1 ring
- PCG6 PE: 600 cc cup + lid
- Central gravity Gun Holder
- Impact Controller
- Cleaning brushes - spanner

**EXAMPLE**



## REFINISHING KIT PRO

- High T.E.C. Spray Gun
- M&S CUP (600 cc):
  - 3 cups + 3 inner lids + 3 knobs + 3 plugs
  - 1 paint filter 125  $\mu$
  - 1 paint filter 250  $\mu$
  - 1 screen paint filter 125  $\mu$  for inner lid
  - 1 cup holder + 1 ring
- PCG6 PE: 600 cc cup + lid
- Cleaning brushes - spanner

**EXAMPLE**



## SPRAY GUN CASE COMBINATION

- Plastic Gun Case for Mix & Spray Cup
- High T.E.C. Manual Spray Gun W400 142G  $\varnothing$ 1.4 Gravity Feed LV2
- AZ 3 HTE Gravity Spray Gun
- AZ 40 HTE Gravity Spray Gun with 200 cc Cup
- Air Regulator with pressure gauge

**EXAMPLE**







**iwata**  
**CM**  
**Custom Micron**  
*Absolute Precision for the Elite Professional*

**Hi-Line**  
Hi-Control of Hi-Precision Work  
**iwata**

**iwata**  
**High Performance**  
High-Precision, High-Detail Work  
**plus**

**iwata**  
**Eclipse**

Ultimate Versatility, Reliability and Performance

**iwata**  
**Revolution**

Quality, Performance and Value

**iwata** COMPRESSORS

**MEDEA**



Our airbrush range is worthy of your attention:  
it has been chosen by some of the top  
and renowned artists in the world.

Artists trust IWATA because they know  
they can find in our products  
the quality they are expecting.

In order to help them express  
their ideas and emotions,  
we produce and distribute  
the most innovative high quality airbrushes,  
designed and tested by artists for artists.

While all Iwata products are designed  
and manufactured  
to the highest standards  
without compromise,  
each series has a distinct advantage  
for different types of applications.



**iwata**



For the elite professional who demands precise and accurate control of very detailed spraying the Custom Micron Series is built to be the "best of the best" hand-tested and adjusted by the world's leading airbrush technicians.



### CM-C PLUS

- Ø 0,23
- Capacity: 7,0 ml
- Type: double action
- Replaceable Teflon™ needle packing
- Pre-set cut-away handle
- Adjustable main lever tension



### CM-C

- Ø 0,23
- Capacity: 9,0 ml
- Type: double action
- Pre-set handle
- Adjustable main lever tension
- Crown cap



### CM-B

- Ø 0,18
- Capacity: 1,8 ml
- Type: double action
- Pre-set handle
- Adjustable main lever tension
- Crown cap



### CM-SB

- Ø 0,18
- Capacity: 3,8 ml
- Type: double action
- Pre-set handle
- Adjustable main lever tension
- Crown cap

### RIGHT OR LEFT HAND CUP POSITION

USE										
CM-C Plus										
CM-C										
CM-B										
CM-SB										



Renowned as the professional's workhorse the popular High Performance Series has been improved and renewed with these inspired new features:

- Dual-purpose, cutaway and pre-set handle for easy clean up and precise control of paint flow
- Teflon™ needle packing for automotive or other solvent-based paints
- Larger threads on the nozzle offer a more secure fit and better centering of the nozzle
- Redesigned tapered gravity-feed cups ensure easy clean up and more efficient paint flow
- Single-piece auxiliary lever/needle-chucking guide provides easy assembly

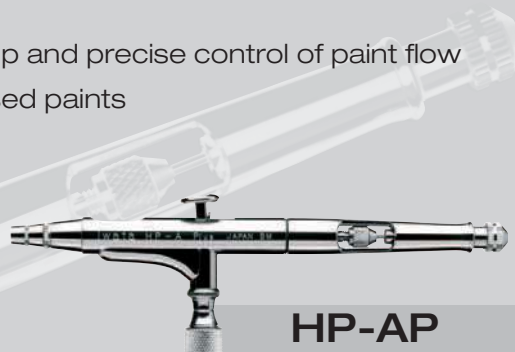

**HP-AP**

- Ø 0,20
- Capacity: 0,4 ml
- Type: double action



**HP-BP**

- Ø 0,20
- Capacity: 1,5 ml
- Type: double action



**HP-CP**

- Ø 0,30
- Capacity: 7,0 ml
- Type: double action



**HP-SBP**

- Ø 0,20
- Capacity: 1,5 ml
- Type: double action



**HP-BC1P / HP-BC2P**

- Ø 0,30
- Capacity: 20 ml
- Type: double action



USE														
HP-AP														
HP-BP														
HP-CP														
HP-SBP														
HP-BC1P/2P														





Designed for artists of all levels, the REVOLUTION line of airbrushes represents the highest quality at a reasonable price. As a result of high technology and high performance, these airbrushes are by far, more superior than others found in the same price range.



**HP-BR**

- Ø 0,50
- Capacity: 1,5 ml
- Type: double action



**HP-CR**

- Ø 0,50
- Capacity: 7,0 ml
- Type: double action



**HP-AR**

- Ø 0,30
- Capacity: 0,4 ml
- Type: double action



**HP-BCR**

- Ø 0,50
- Capacity: 28 ml (bottle type)
- Type: double action



**HP-SAR**

- Ø 0,50
- Capacity: 28 ml (bottle type)
- Type: single action



**HP-TR1**

- Ø 0,30
- Capacity: 7,0 ml
- Type: double action



**HP-TR2**

- Ø 0,50
- Capacity: 15 ml
- Type: double action

USE														
HP-AR	Red	Red	Red	Red	Red	Red	Red	Red	Red	Red	Red	Red	Red	Red
HP-BR	Red	Red	Red	Red	Red	Red	Red	Red	Red	Red	Red	Red	Red	Red
HP-CR	Red	Red	Red	Red	Red	Red	Red	Red	Red	Red	Red	Red	Red	Red
HP-BCR	Red	Red	Red	Red	Red	Red	Red	Red	Red	Red	Red	Red	Red	Red
HP-SAR	Red	Red	Red	Red	Red	Red	Red	Red	Red	Red	Red	Red	Red	Red
HP-TR1	Red	Red	Red	Red	Red	Red	Red	Red	Red	Red	Red	Red	Red	Red
HP-TR2	Red	Red	Red	Red	Red	Red	Red	Red	Red	Red	Red	Red	Red	Red

Now available for the beginning or casual airbrush user, Iwata Studio Series Compressors utilize the latest technology to fulfill your every airbrushing need. It has never been easier to start with Iwata since all Studio Series Compressors are sold complete with fittings, filters, airhoses and an adapter to fit any airbrush.



## IS 50 Silver Jet

- Motor: W 140-110
- Max. pressure bar: 1,3
- Air delivery l/min: 9,3
- Mass kg: 2,9
- Dimensions: mm 150 x 155 x180
- Standard 4m coil hose (HPA-CH41)



## IS 850 Smart Jet

- Motor W 91
- Max. pressure bar 2,4
- Air delivery l/min 18
- Mass kg 3,6
- Dimensions mm 250 x 180 x 160
- Standard 3m air hose (HPA-SH32)



## IS 875 Smart Jet Pro

- Motor W 91
- Max. pressure bar 2,4
- Air delivery l/min 18
- Mass kg 6,4
- Dimensions mm 265 x 310 x 155
- Standard 3m air hose (HPA-SH32)



## IS 925 Power Jet Lite

- Motor W 125
- Max. pressure bar 4,8
- Air delivery l/min 34
- Mass kg 7,9
- Dimensions mm 265 x 310 x 155
- Standard 3m air hose (HPA-SH32)



## IS 975 Power Jet Pro

- Motor W 125
- Max. pressure bar 4,8
- Air delivery l/min 34
- Tank size 2L
- Mass kg 11,9
- Dimensions mm 330 x 230 x 180
- Standard 3m air hose (HPA-SH32)



*iwata studio series*



### Smart Jet Technology

- Compressor shuts itself off automatically when not in use
- Less heat-related moisture build-up
- Produces full-capacity air on demand
- Reduces running time
- Less motor wear means longer compressor life
- Inherently quieter in public environments



### 2x Sprint Jet Power

- Zero-maintenance, oil-less piston compressor
- Powerful 1/6-hp motor
- Airflow 1.2 CFM (34pmM)





# Freehand™ AIRBRUSH TEMPLATES

**SOLVENT PROOF!**  
Easily used with water-based  
and solvent-based paints.

The Artool™ Freehand™ Airbrush Templates are a real asset to anyone who uses an airbrush. These SOLVENT PROOF templates can be easily flexed or curved around irregular shaped surfaces and cleaned with solvents without being damaged. Delineate shapes by matching the contours of the Freehand™ Airbrush Templates with the subject matter. Simply rotate or flip-flop the Freehand™ Airbrush Templates to find the shape that works best or raise the template slightly to create a soft edge. However you use these templates, you're sure to create something great!





# iwata

# MEDEA

## Nail - Art

Nail painting has reached levels of intricacies that had only been dreamed about before the advent of the airbrush. Today, detailing nails is easier than ever with the fine, precise control of Iwata airbrushes.



## Body - Art

The airbrush has become a significant tool for progressive beauty professionals. It is commonly used in the film industry and is now finding a home in the modern make-up artist's repertoire, creating flawless glamour looks on all skin types, including difficult complexions.

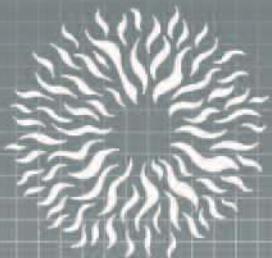

# Environmental Protection Act

**THATCHAM**  
THE MOTOR INSURANCE  
REPAIR RESEARCH CENTRE

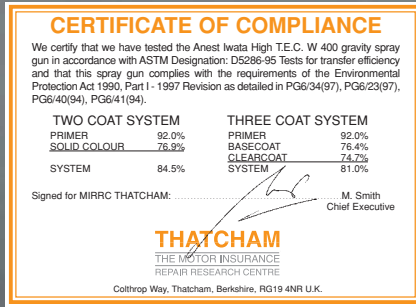

Anest Iwata Spray Guns

W 200  
W 300  
W 400  
W 400 WB  
WA 100  
WA 200  
WRA 200

Airgunsa Spray Guns

AZ3 HTE  
AZ10 HTE  
AZ40 HTE

# IPA Fraunhofer Certification



Anest Iwata Spray Guns

W 400  
W 400 WB  
NEW 71  
NEW 77

Airgunsa Spray Guns

AZ 30 HTE

# CE ATEX Declaration Of Conformity

European Directives: 1994/9/CE - 1999/92/CE

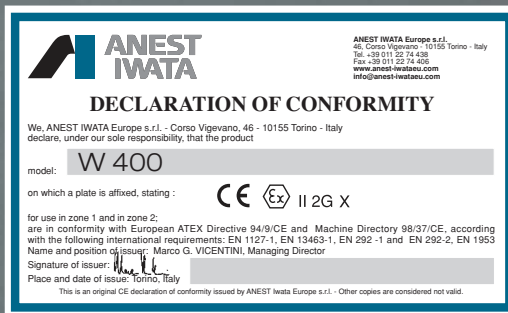

CE mark permitted by the European Commission to show compliance with all EU directives applicable to a product.

ATEX mark to show suitability for explosive atmospheres.

Product group II (Surface equipment)

Explosion risk due to presence of GAS

Special precautions in instruction manual.

ALL PRODUCTS



Presence of EXplosive ATmosphere	zone	product category
Constant	0	1
Occasional	1	2
Minimum/Short period	2	3

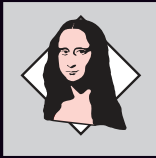

- Illustrators
- Illustrazione
- Illustration

Fine Art  
Belle Arti  
Beaux Arts

Photo retouchers  
Fotoritocco  
Retouches de photo

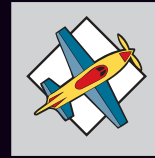

- Planes
- Aeromodellismo
- Aéromodélisme



- Students
- Studenti
- Étudiants

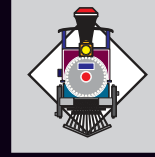

- Trains
- Trenini
- Trains



- Textile - T-shirts
- Tessuti - T-shirt
- Textile - T-shirts



- Figurines - Miniatures
- Soldatini - Miniature
- Figurines - Miniatures



- Ceramics
- Ceramica
- Céramique



- Model builders - Dioramas
- Prototipi - Diorama
- Maquettes - Modèles réduits



- Murals
- Murales
- Muraux

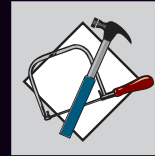

- Hobby - Craft
- Hobby - Artigianato
- Hobby - Artisanat

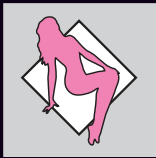

- Body- Art
- Body- Art
- Tatouage éphémère



- Wood carving
- Intarsio e pittura legno
- Sculpture sur bois



- Nail- Art
- Nail- Art
- Onglerie



- Taxidermy
- Tassidermia
- Taxidermie



- Tanning
- Abbronzanti
- Bronzage



- Sign painting
- Insegne e cartellonistica
- Enseigne et signalisation



- Cosmetics
- Cosmetica
- Maquillage



- Auto graphics
- Aerografia auto
- Tuning



- RC cars
- Automodellismo dinamico
- Voitures télécommandées



- Spot repair
- Piccole riparazioni
- Petites réparations



- Plastic
- Plastica
- Kunststoff
- Kunststof
- Plast
- Plástico
- Plástica



- Nozzle orifice
- Diametro ugello
- Buse
- Düsendurchmesser
- Munstycksdiameter
- Diámetro pico
- Diâmetro do bico

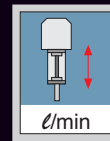

- Delivery/cycle
- Portata per ciclo
- Volume/cycle
- Durchsatz/Zyklus
- Mängd/cykel
- Reparto/ciclos
- Ciclo da entrega



- Furniture
- Mobili
- Meubles
- Möbel
- Möbel
- Muebles
- Mobiliário

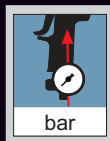

- Air pressure
- Pressione aria
- Pression d'air
- Luftdruck
- Lufttryck
- Presión aire
- Pressão de ar



- N° of cycle per minute
- N° di cicli al minuto
- N° de cycle/min
- Anzahl Zyklen/Minute
- Antal cykler per minut
- N° de ciclos por minuto
- Numero de ciclos por minuto

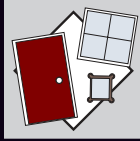

- Door/window-frames
- Serramenti
- Chassis porte/fenêtre
- Türen/Fensterrahmen
- Dörröch fönster
- Puertas/marcos ventanas
- Porta/janelas

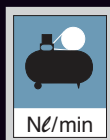

- Air consumption
- Consumo aria
- Débit d'air
- Luftverbrauch
- Luftförbrukning
- Consumo aire
- Consumo de ar

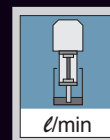

- Max fluid delivery
- Portata massima fluido
- Débit maximum
- Max. Materialdurchsatz
- Max. material utsläpp
- Caudal máximo de fluido
- Máximo fluido de distribuição



- Footwear
- Calzature
- Chaussures
- Schuhe
- Skor
- Calzado
- Sapatos

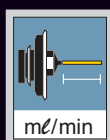

- Fluid output
- Uscita materiale
- Débit produit
- Materialausfluss
- Material flöde
- Producción material
- Saida de material

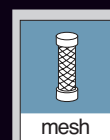

- Suction filter
- Filtro in aspirazione
- Filtre aspiration
- Filter f. Saugsystem
- Sugfilter
- Filtro succión
- Mala do filtro



- Leather
- Pelletteria
- Cuir
- Leder
- Läder
- Cuero
- Peles



- Pattern width
- Larghezza ventaglio
- Largeur de jet
- Spritzstrahlbreite
- Sprutbredd
- Ancho abanico
- Largura de leque



- Suction filter
- Filtro in aspirazione
- Filtre aspiration
- Filter f. Saugsystem
- Sugfilter
- Filtro succión
- Mala do filtro



- Chairs
- Sedie
- Chaises
- Stühle
- Stolar
- Sillas
- Cadeiras



- Air cap set
- Ugello aria
- Chapeau
- Luftdüse
- Luftmunstycke
- Boquilla
- Espalhador

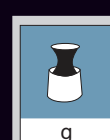

- Weight
- Peso
- Poids
- Gewicht
- Vikt
- Peso
- Peso



- Body shop
- Carrozzeria
- Carrosserie
- Karosseriewerkstatt
- Bil
- Carroceria
- Carroçaria



- Max. fluid pressure
- Max. pressione materiale
- Pression maxi. produit
- Max. Materialdruck
- Max. material tryck
- Máxima presión fluido
- Máxima pressão do bico

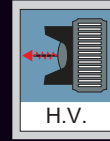

- Gun inlet voltage
- Voltaggio in entrata
- Tension d'entrée
- Eingang Spannung
- Ingående spänning
- Voltaje entrada



- Ceramics
- Ceramica
- Céramique
- Keramik
- Keramik
- Cerámica
- Cerâmica

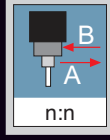

- Pressure ratio
- Rapporto di pressione
- Rapport de pression
- Druckangabe
- Tryckförhållande
- Relación de presión
- Pressão de proporção



- Gun outlet voltage
- Voltaggio in uscita
- Tension sortie
- Ausgang Spannung
- Utgående spänning
- Voltaje salida



- Car assembly
- Montaggio auto
- Construction auto
- Fahrzeugmontage
- Bil monterig
- Automoción
- Montagem de carros



- Max fluid pressure
- Pressione massima fluido
- Pression maxi. produit
- Max. Materialdruck
- Max. material tryck
- Máxima presión fluido
- Máxima pressão de saída

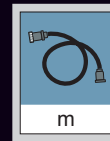

- Hose length
- Lunghezza tubo
- Longueur tuyau
- Schlauchlänge
- Slang längd
- Largo cable



- Ship building
- Industria navale
- Industrie navale
- Schiffbau
- Varvsindustri
- Industria naval
- Industria naval

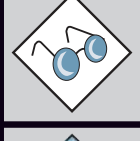

- Glasses
- Occhiali
- Lunettes
- Glas
- Glasogon
- Vidros
- Cristales



- General industry
- Industria generica
- Industrie générale
- Allgemeine Industrie
- Generell industri
- Industria general
- Industria geral



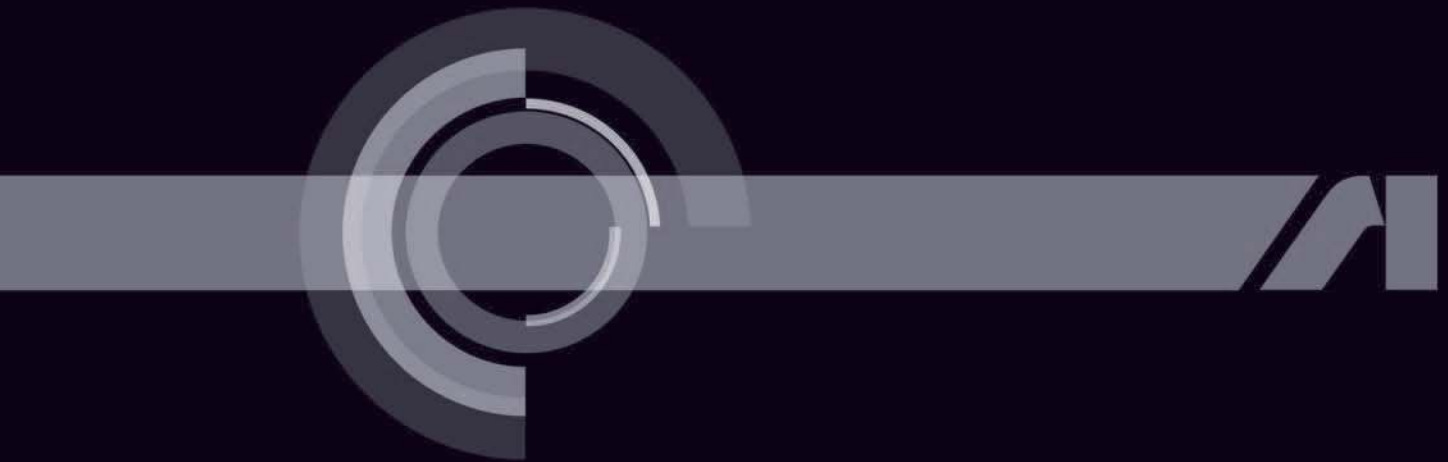



**ANEST IWATA Italia**

Corso Vigevano, 46  
10155, Torino - Italy  
Tel.+39 011 22 74 400/3  
Fax +39 011 85 19 44

info@anest-iwata.it  
www.anest-iwata.it



**ANEST IWATA France**

25 rue de Madrid  
38070 Saint Quentin Fallavier - France  
Tél. +33 (0)4 74 94 59 69  
Fax +33 (0)4 74 94 34 39

info@anest-iwata.fr  
www.anest-iwata.fr



**ANEST IWATA U.K.**

Unit 10, Little End Road, Eaton Socon  
St. Neots, Cambridgeshire - PE19 8JH  
Tel. +44 (0)1480 40 54 19  
Fax +44 (0)1480 21 76 10

enquiries@anest-iwata.co.uk  
www.anest-iwata.co.uk



**ANEST IWATA Scandinavia**

Ögärdesvägen 6C,  
433 30 PARTILLE - Sweden  
Tel. +46 31 340 28 60  
Fax +46 31 340 28 69

info@anest-iwata.se  
www.anest-iwata.se



**ANEST IWATA Europe**

**Sucursal España y Portugal**  
Avda.del Maresme, 44-46 Planta 2 OF. 25  
08918 - Badalona - Barcelona  
Tel. +34 93 32 05 993  
Fax +34 93 32 05 564

info@anest-iwata.es  
www.anest-iwata.es



**ANEST IWATA Europe**

**Niederlassung Deutschland**  
Dorfäckerstr.23/1, 74248 Ellhofen  
Tel. +49 (0)7134 91 73 68  
Fax +49 (0)713491 73 78  
Handy: +49 (0)172 62 74 542

info@anest-iwata.de  
www.anest-iwata.de



**ANEST IWATA Europe**

Corso Vigevano, 46  
10155, Torino - Italy  
Tel.+39 011 22 74 438  
Fax +39 011 22 74 406

info@anest-iwataeu.com  
www.anest-iwataeu.com



**ANEST IWATA CORP.**

Yokohama - JAPAN  
www.anest-iwata.co.jp



**ANEST IWATA CORP.**

Akita - JAPAN  
www.anest-iwata.co.jp



**AIR GUNSA s.r.l.**

Cardano al Campo (VA) - ITALY  
www.airgunsa.com

